

EI Series Bimetal Thermometers

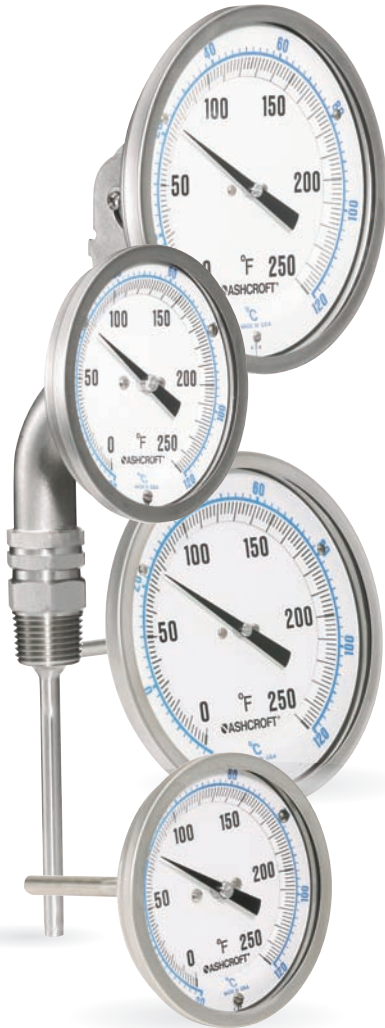

FEATURES

- 1% full span accuracy (ASME B40.3 Grade A)
- Maximum ambient temp. is 200°F (94°C)
- Hermetically sealed case to prevent entry of moisture, interior corrosion and coil freeze-up.
- External adjustment permits zero reset from outside the case.
- Maxivision® dial allows readability from any angle without parallax error.
- Silicone coil dampening (up to 400°F) provides vibration dampening and improves response time.
- All-welded stainless steel construction
- Heavy-Duty glass lens
- Protection IP 65
- Five year limited warranty



SPECIFICATIONS

Ashcroft® Series:	EI																						
Dial Sizes:	2", 3", 5"																						
Stem Length:	2½"–24" ⁽¹⁾																						
Case & Stem:	304 stainless steel, hermetically sealed																						
Stem Dia:	.250"																						
Window:	Heavy-duty glass, plastic or shatter-proof glass optional																						
Dial:	Maxivision®, black figures on white background																						
Pointer:	Black																						
Connection:	Plain, pointed plain, ¼ NPT, ½ NPT, ½ NPT union																						
Connection Location:	Everyangle, Lower, Rear																						
Ranges:	-80/120°F — 200/1000°F -50/50°C — 100/500°C																						
Options:	<table border="0"> <tr> <td>Code</td> <td>Description</td> </tr> <tr> <td>C4</td> <td>Individual calibration cert.</td> </tr> <tr> <td>XCS</td> <td>Dual scale⁽²⁾</td> </tr> <tr> <td>XDM</td> <td>Dial marking</td> </tr> <tr> <td>XNH</td> <td>Stainless steel tag</td> </tr> <tr> <td>XNN</td> <td>Paper tag</td> </tr> <tr> <td>XPD</td> <td>Plastic window</td> </tr> <tr> <td>XSG</td> <td>Shatter proof glass</td> </tr> <tr> <td>X3B</td> <td>¾" stem dia. with ½ NPT</td> </tr> <tr> <td>X02</td> <td>¼ NPT when ½ NPT is standard</td> </tr> <tr> <td>XS1</td> <td>Silicone free</td> </tr> </table>	Code	Description	C4	Individual calibration cert.	XCS	Dual scale ⁽²⁾	XDM	Dial marking	XNH	Stainless steel tag	XNN	Paper tag	XPD	Plastic window	XSG	Shatter proof glass	X3B	¾" stem dia. with ½ NPT	X02	¼ NPT when ½ NPT is standard	XS1	Silicone free
Code	Description																						
C4	Individual calibration cert.																						
XCS	Dual scale ⁽²⁾																						
XDM	Dial marking																						
XNH	Stainless steel tag																						
XNN	Paper tag																						
XPD	Plastic window																						
XSG	Shatter proof glass																						
X3B	¾" stem dia. with ½ NPT																						
X02	¼ NPT when ½ NPT is standard																						
XS1	Silicone free																						

(1) Special or longer length available, consult factory
 (2) Dual scale available with 3" and 5" case only
 (3) Only available on rear connection

Thermowells must be used on all pressure or velocity applications, to protect the stem of thermometer from corrosion and physical damage, and to facilitate removal of the thermometer without disturbing the process. Maximum ambient temperature is 200°F (95°C).

HOW TO ORDER

30 EI 60 R 040 0/250°F XNH

Dial Size: 3" Code 30	_____
Case Style: EI	_____
Stem Connection: ½ NPT Code 60	_____
Stem Location: Rear Code R	_____
Stem Length: 4" Code 040	_____
Range: Code 0/250°F	_____
Options: Stainless steel tag	_____

EI Series Bimetal Thermometers

EI Series selection table																		
Case	Size	Dial Code	Style Code	Stem			Stem Lengths Available "S"			Temperature Range								
				Conn.	Code	Location	Code	Length (inches)	Code	°F* Fahrenheit	% Div.	Fig. Inter.	°C Celsius	% Div.	Fig. Inter.			
2"	20			Plain	40	Rear	R	2½	025	-80/120	2	20	-50/50	1	10			
				Pointed	50					-20/120††			-20/120			2	20	
				½ NPT	60					30/130††			1			10	0/50††	1
3"	30			½ NPT Union	42	Everyangle	E	4	040	0/200	20	10/150	2	20				
				½ NPT	60										0/100	1	10	
				½ NPT	60	Rear	R	9	090	0/250	50	0/200	5	50	0/300††	5	50	
						Lower	L											12
5"	50			½ NPT Union	42	Everyangle	E	15	150	50/400	5	50	0/300††	5	50			
				½ NPT	60											50/550	100/500**††	
				½ NPT	60	Rear	R	18	180	200/700†	100/800†	200/1000**††	10	100				
						Lower	L											

EI Series dual scale ranges

Dual scales are available in 3" and 5" dial sizes in the following ranges:

Inner	Outer
-80/120°F	and -60/50°C
-40/120°F	and -40/50°C
-40/160°F	and -40/70°C
-20/120°F	and -30/50°C††
0/200°F	and -20/90°C
0/250°F	and -20/120°C
30/130°F	and 0/55°C††
50/300°F	and 10/150°C
50/400°F	and 10/200°C
50/550°F	and 10/290°C
100/800°F	and 50/400°C†
200/700°F	and 100/370°C†
200/1000°F	and 100/550°C**†

EI Dimensions													
Case Series	Dial Size	Connection Location	A	B	C	D	E	G	H	S	NPT	Hex	Weight in ounces ⁽³⁾
													S - 2½"
EI	2"	Rear (Plain)	2¾ (53)	¾ (10)	¾ (8)	-	-	-	-	-(2)	-	1¼	4½
EI	2"	Rear (Plain, pointed stem)	2¾ (53)	¾ (10)	¾ (8)	-	-	-	-	-(2)	-	1¼	4½
EI	2"	Rear (Threaded)	2¾ (53)	¾ (10)	¾ (8)	-	-	-	-	-(2)	¼	1¼	4½
EI	3"	Rear	3¾ (80)	1½ (15)	¾ (8)	-	-	-	-	-(2)	½	¾	7
EI	3"	Lower	3¾ (80)	1¾ (47)	-	2½ (67)	¼ (6)	-	-	-(2)	½	¾	11
EI	3"	Everyangle	3¾ (80)	1½ (15)	-	-	-	1¾ (42)	3¼ (89)	-(2)	½	¾	10
EI	5"	Rear	5½ (128)	2¾ (18)	¾ (8)	-	-	-	-	-(2)	½	¾	16
EI	5"	Lower	5½ (128)	1¾ (49)	-	3½ (92)	¼ (6)	-	-	-(2)	½	¾	26
EI	5"	Everyangle	5¼ (128)	2¾ (18)	-	-	-	1¾ (48)	3¾ (93)	-(2)	½	¾	25

NOTES:

- Figures in parenthesis () are in millimeters. All other dimensions are in inches.
- Standard "S" dimensions are 2½, 4, 6, 9, 12, 15, 18 and 24 inches. Standard stem diameter is ¼ inch.
- Add 1 oz. for every 2 inches of stem length.

Overtemperature limits

Top of Range °F	Maximum Over Temperature
up to 250	100% of span
251/550	50% of span
551/1000	800°F **

*Dual scale ranges available for all standard °F ranges (3" and 5" case only)

**Satisfactory for continuous service up to 800°F or 425°C. Can be used for intermittent service from 800 to 1000°F, or 425 to 500°C. Use Ashcroft Duratemp® thermometers for ranges above and below those listed above.

†Minimum stem length for these ranges is 4".

††Minimum stem length for lower connection and Everyangle is 4".

DIMENSIONS

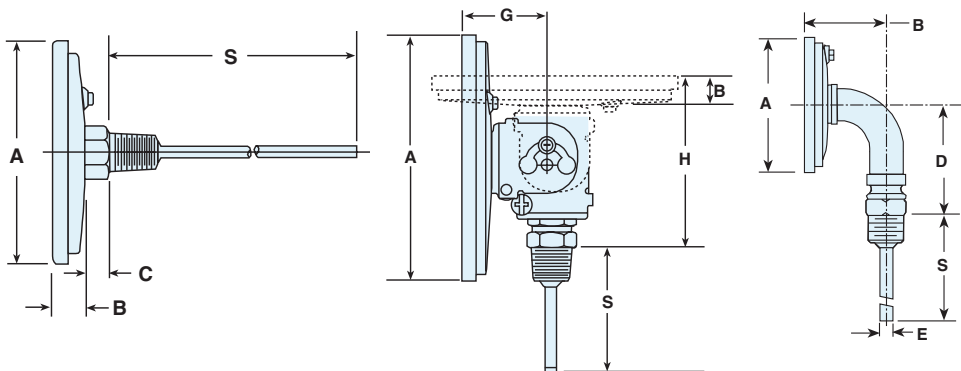

TRANSCAT®
 35 Vantage Point Drive
 Rochester, NY 14624
 1.800.800.5001